

# ECONORED I INFRARED DRYER

## Features:

- 10 Year Heater Warranty<sup>1</sup>.
- Three system control variables
  1. Variable DC belt speed control
  2. Digital PID temperature control
  3. Infrared focusing.
- New exclusive "X-Series" belt tracking system.
- Teflon coated 30" wide fiberglass belt.
- 2 to 7 inch belt-to-heater clearance.
- Wide feed and exit openings.
- 3500 watts high output heater.
- User friendly diagnostic pilot lights.
- Easy lift off heat chamber for transportation.
- 150+ pieces per hour per chamber<sup>2</sup>
- Expandable in the field! Add chambers and / or belt extensions.
- Costs just 21 cents per hour<sup>3</sup> per chamber to operate.



## EC-I (single chamber)

EC-I  
30" belt x 5 1/2' long  
150+ pcs / hr



## Options:

- Additional chambers can be added in 20" increments.
- Belt extensions can be added in 18" increments.
- Powered exhaust
- 240 Volt Conveyor.
- Casters for easy mobility.
- Laser temperature gun.



Digital PID Temperature Controls

Diagnostic Pilot lights

Heater On/Off Switch

DC Belt Speed Control



*Our Warranty Says It All!*

1032 North Irving Street  
Allentown, PA 18109-1846  
USA

Phone: +1.610.434.6004  
Toll Free: 1.800.482.7839  
Fax: +1.610.434.6607

WWW.VASTEX.COM

# The Most Reliable & Powerful Dryers In The Industry!

## Did You Know?

With over 40+ years in the screen printing industry, Vastex has the knowledge and experience to provide the most reliable and powerful dryers in the industry.

The EconoRed I is a **HIGH OUTPUT** dryer that is compact, expandable and easy to transport (through doorways and stairs)! If you're cramped for space but still have high production demands, the EconoRed I could be the dryer for you. If you need to increase production, it's as easy as dropping a new chamber into the system and belt extensions can also easily be added in 18" increments.

Adding a power exhaust can help to keep your environment cool and free of fumes. Want to stay 'one' up on your competition? Visit [www.vastex.com](http://www.vastex.com) to learn more about the EconoRed I.

## Technical Specifications

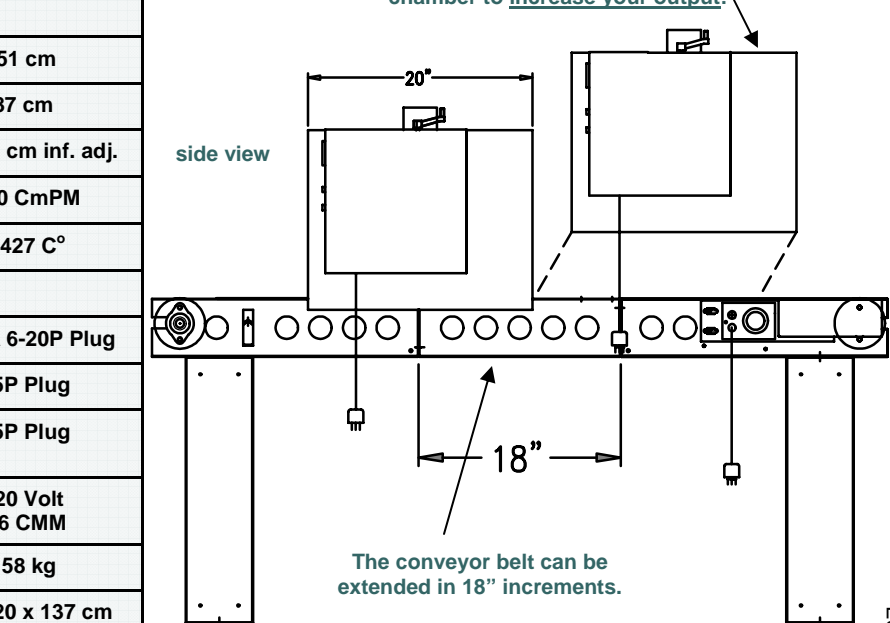
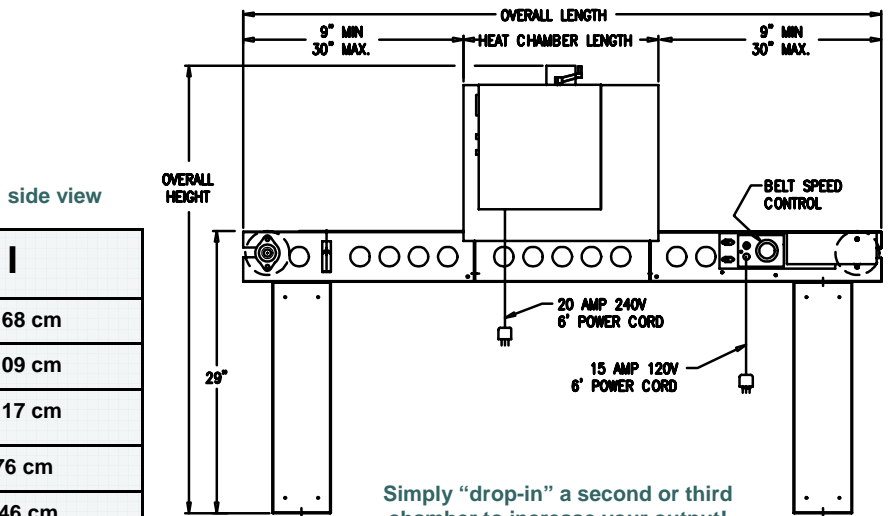
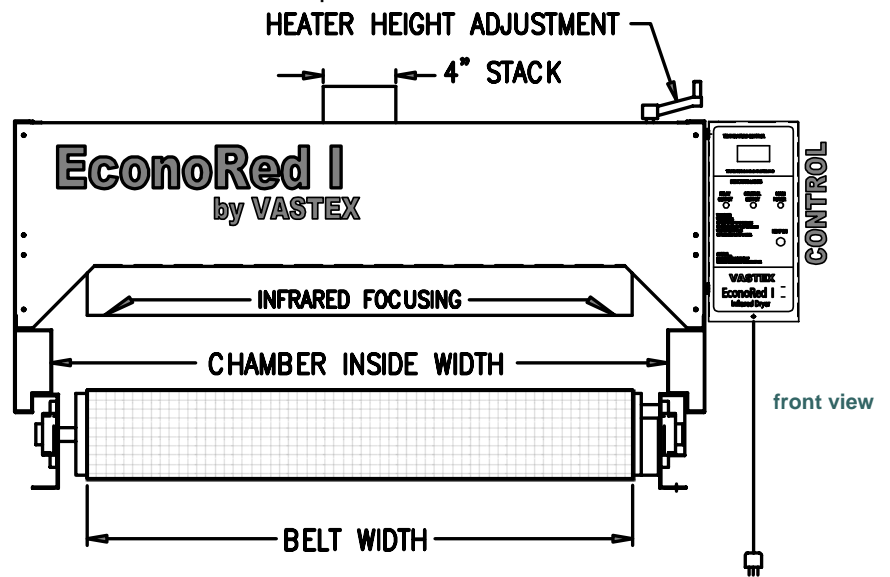

## EconoRed I

Overall Length	66"	168 cm
Overall Width	43"	109 cm
Overall Height	46"	117 cm
Belt Width	30"	76 cm
Heater Specs	(1) 24" x 18" / 61 cm x 46 cm @ 3500 watts	
Chamber Length	20"	51 cm
Chamber Inside Width	34 1/2"	87 cm
Chamber Inside Height	2" - 7" inf. adj.	5 - 17.7 cm inf. adj.
Belt Speed	0-12 FPM	0-30 CmPM
Heat Range	0-800 F°	0-427 C°
Shirts / Hr (Plastisol)	150-200	
Electrical Specs - Chamber	240V / 16A / 1 Phase / NEMA 6-20P Plug	
Electrical Specs - Conveyor	120V / 1Amp NEMA 5-15P Plug	
Electrical Specs - Optional 240 Volt Conveyor	240V / 1Amp NEMA 6-15P Plug	
Electrical Specs - Optional Powered Exhaust	120 Volt 200 CFM	120 Volt 5.6 CMM
Shipping Weight	349 lbs	158 kg
Shipping Dimensions	28" x 47" x 54"	71 x 120 x 137 cm

<sup>1</sup> 10 year warranty on all infrared heaters. 3 year "bumper-to-bumper" warranty is on manufacturers' defects.

<sup>2</sup> Cure test done with triple deposit of white ink on black shirts at 200 pcs/hr.

<sup>3</sup> Operating cost based on 6 cents / kwh.